

The product using material and processing must conform to the "WL-PZ-001"HSF technical standard control requirements

RoHS

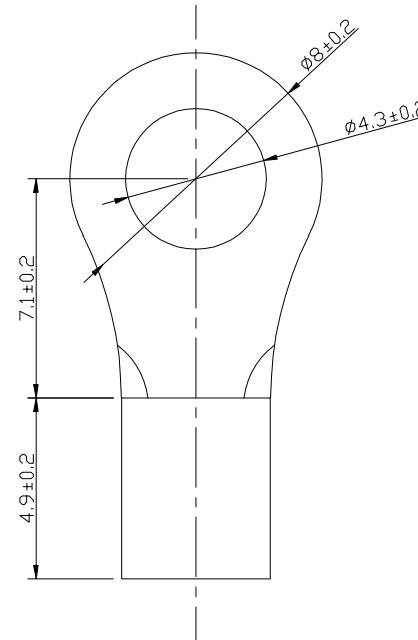
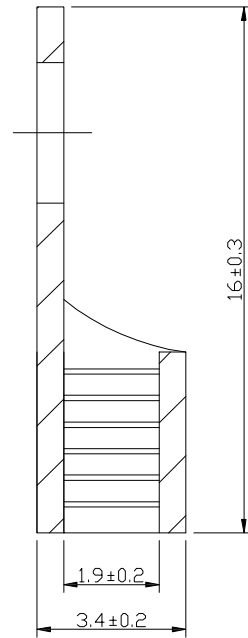

技术要求

- 1、材质：紫铜，厚度0.75mm
- 2、导线截面积：0.5~1.5mm²
- 3、最大电流：19A
- 4、表面处理：镀锡

| REV. | REVISION RECORD | DATE | | GENERAL TOLERANCES | | SCALE: 1:1 | NAME | DATE | PART.NO: | DWG.NO: | |
|------|-----------------|----------|----------|--------------------|----------|---------------|-------------|----------|---------------------------------|---------|-----------------------|
| A0 | NEW RELEASE | 22.10.28 | | LINEAR | ANGLES | APPROVED | Wang_jr | 22.10.28 | RNBL1.25-4 | ENDE05 | |
| | | | UNIT:mm | 0.00±0.25 | X'±3° | DESIGNER | Han_Gao | 22.10.28 | TITLE: 0形无绝缘端子 镀锡 RNBL1.25-4 | | REV: A0 SHEET: 1/1 |
| | | | SIZE: A4 | 0.000±0.10 | X'X' ±2° | DRAWN | LanXuan_Hou | 22.10.28 | | | |

WanLian Technology Co., Ltd

WanLian Technology Co., Ltd

REV: A0 SHEET: 1/1